



# INSTALLATION INSTRUCTIONS

B-445—04/08

Installation—Mounting—Plumbing Instructions for  
Midranger, I-702/I-702B and Linehauler I-703/I-703B  
In-Line Fuel Warmers

## READ INSTRUCTIONS COMPLETELY BEFORE BEGINNING INSTALLATION

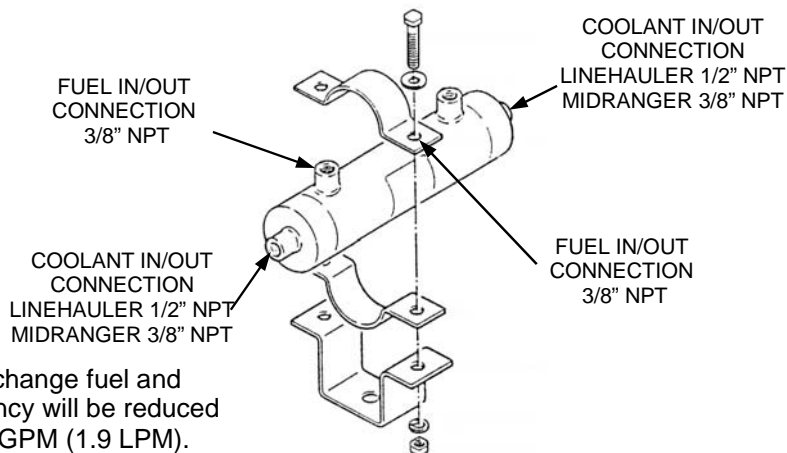
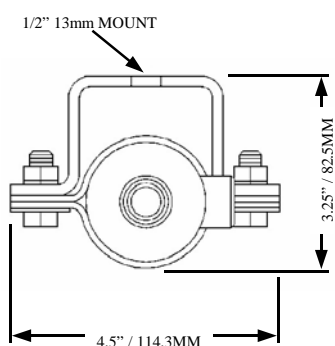

**CAUTION:** While it is physically possible to interchange fuel and coolant connections in pairs, heat transfer efficiency will be reduced by up to 43% on fuel systems which flow over .5 GPM (1.9 LPM).

**MOUNTING:** Using appropriate mounting hardware, the in-line fuel warmer can be frame or engine/transmission mounted in either the horizontal or vertical position. To provide maximum cold weather protection, the in-line warmer must be located as close as possible to the primary fuel filter. Some engine applications may not be equipped with a primary fuel filter between the tank and transfer pump. In this situation, locate warmer as close as possible to the transfer pump.

**COOLANT SUPPLY:** Obtain hot coolant from a pipe plug opening on the engine pressure side of the cooling system. Route coolant to either “COOLANT CONNECTION” on warmer.

**COOLANT RETURN:** Route coolant from unused “COOLANT CONNECTION” on warmer back to engine pipe plug on suction side of engine cooling system. **SUGGESTION:** If uncertain as to which pipe plug ports on an engine are coolant supply and return, locate hose connections for cab heater and plumb into ports located in same cavities.

**FUEL:** Route fuel line from tank to either “FUEL CONNECTION” on fuel warmer. Install fuel line from other fuel connection on warmer to primary fuel filter inlet or to transfer pump if engine is not equipped with a primary filter. If more than 24 inches (610mm) of fuel line is installed between the warmer and filter/pump, it is recommended that the line be insulated with ARCTIC FOX INSULTUBE of the proper inside dimension to fit the line, refer to B-500 product catalog.

**CAUTION:** For the most efficient operation of fuel warmers, it is **recommended** that a separate coolant loop be provided. It is **NOT recommended** to use Tee's or Wye's in coolant supply and return lines thereby paralleling with another accessory. However, if all access ports on the engine are being used for other accessories, such as cab or sleeper heaters or coolant sensors, the a Tee or Wye may have to be considered as an option. In this circumstance, the Tee/Wye must be at least 1/2" NPT or larger and should be installed at the engine port, not along the coolant line itself. It should also be noted that plumbing a fuel warming device in series with a cab heater may drastically reduce the amount of heat transferred to the fuel. Hot coolant should be shutoff to the fuel warmer when ambient temperatures reach 40° Fahrenheit (4° Celsius). Manual shut off valves such as Arctic Fox part numbers A-275, A-461, A-526, or A-527 and automatic shut off valve number S-400T are available from your dealer.

**HELPFUL HINTS:** If an in-line fuel warmer is used with an optional in-tank warmer, both can be plumbed in series in the same coolant loop. However, the hot coolant from the engine coolant supply should first pass through the in-line warmer, then on to the in-tank warmer. This will allow maximum anti-waxing protection to the primary fuel filter upon initial startup after an extended “cold soak” period. For additional cold weather protection, especially below 0° F (-18°C), Arctic Fox Insultube can be added to all fuel and coolant lines to reduce external heat loss. Refer to the Arctic Fox product catalog for all installation accessories or call (800) 654-5382 for additional information or assistance.

See Warranty Information on reverse

## **FUEL AND FLUID WARMER WARRANTY(COOLANT)**

All Arctic Fox<sup>®</sup> warmers (other than engine oil pan heat exchangers and alternative fuel heat exchangers) using coolant are warranted against defects in materials and workmanship for a period of 5-years or 600,000 miles from the date of purchase by the user. This warranty does not cover warmers which are altered or used for a purpose other than that for which it was intended or used in a manner inconsistent with any instructions regarding its use. The exclusive remedy for any unit found to be defective under this warranty is limited to the repair or replacement of the defective unit without charge, and Arctic Fox<sup>®</sup> shall **NOT** be liable for any consequential or incidental damages, including labor.

## **WARRANTY RETURN PROCEDURE**

In order to qualify for stated warranties, a Return Goods Authorization (RGA) number must be obtained from Arctic Fox<sup>®</sup> by calling (in USA) 1-800-654-5382 or 763-972-2758. The alleged defective unit must be returned to Arctic Fox<sup>®</sup> intact, postage or freight prepaid and Arctic Fox<sup>®</sup> will return the repaired or replaced unit postage or freight prepaid. Final determination of defects shall be made by Arctic Fox<sup>®</sup> in accordance with procedures established by Arctic Fox<sup>®</sup>. No agent, employee or representative of Arctic Fox<sup>®</sup> has any authority to bind any affirmation representation or warranty concerning Arctic Fox<sup>®</sup> products except as stated herein. There are no warranties that extend beyond the description of the express non-customer product warranty as stated. The warranty is in lieu of any other warranty, express or implied, and expressly excludes any warranty of merchantability or fitness for a particular purpose. To obtain performance of this limited warranty, the alleged defective product must be returned, together with reasonable proof of purchase, postage or freight prepaid, directly to (in USA):

Warranty Department  
Arctic Fox, LLC  
570 South 7th Street  
Delano, MN 55328